

ZURRSCHIENEN BESTELLFORMULAR

Zurrschienen LRB, OEM Fiat, quer, Oberflur/Unterflur, lotrecht unter Dachholm

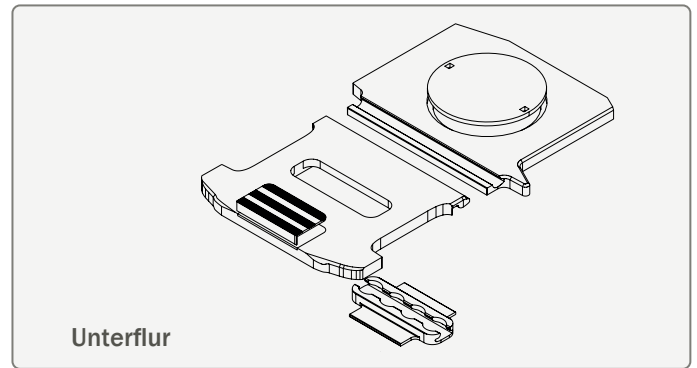

Bitte wählen Sie:

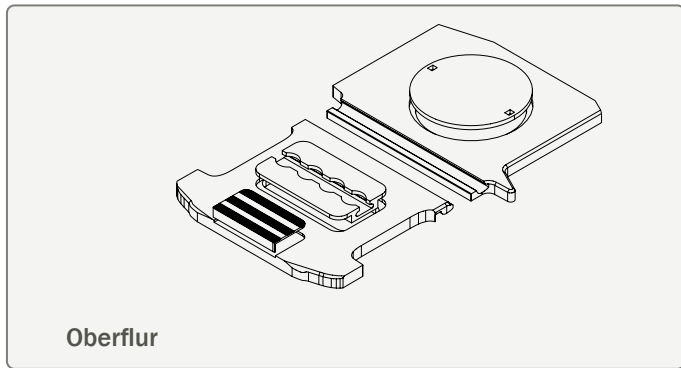

Scudo	L1	CVE Modell (Typ)
RS: 3000		124

Scudo	L2 H1	CVE Modell (Typ)
RS: 3122		125

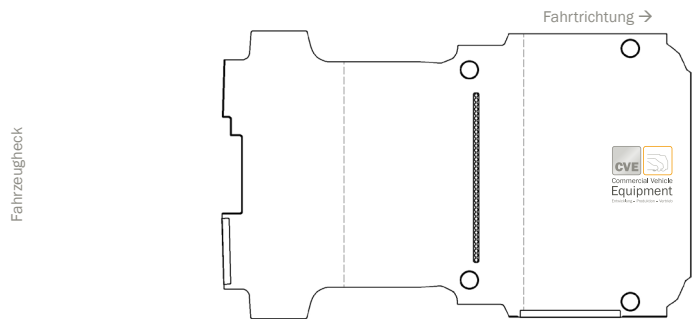
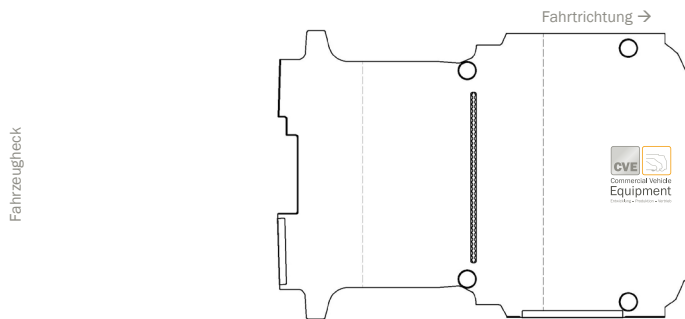

Scudo	L2 H2	CVE Modell (Typ)
RS: 3122		125

Talento (X82)	L1	CVE Modell (Typ)
RS: 3098		164

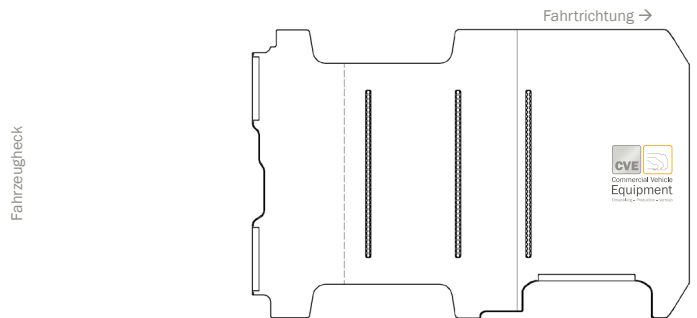
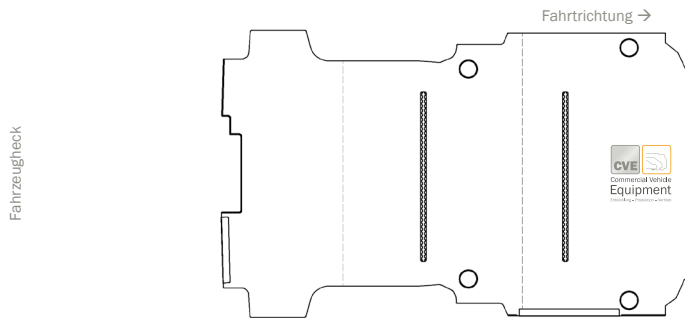

Talento (X82)	L2	CVE Modell (Typ)
RS: 3498		165

Talento (X82)	L2 H2	CVE Modell (Typ)
RS: 3498		165

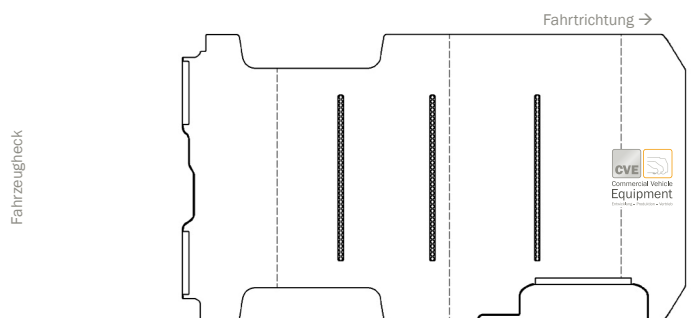
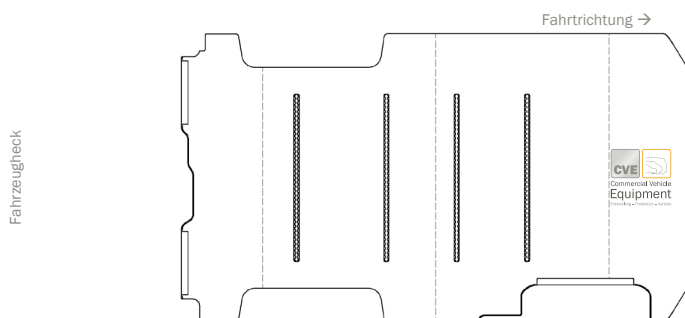

ZURRSCHIENEN BESTELLFORMULAR

Zurrschienen LRB, OEM Fiat, quer, Oberflur/Unterflur, lotrecht unter Dachholm

Commercial Vehicle
Equipment
Entwicklung - Produktion - Vertrieb



Ducato	L1	CVE Modell (Typ)
RS: 3000		120

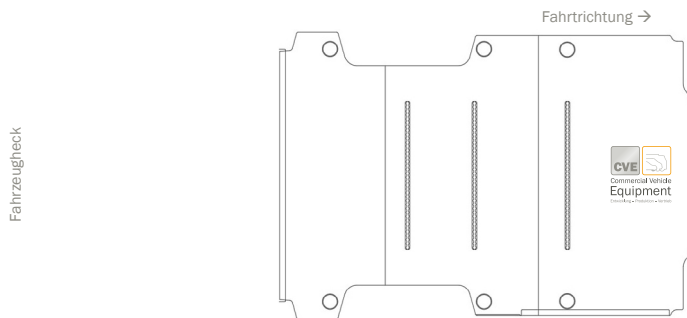

Ducato	L2	CVE Modell (Typ)
RS: 3450		121

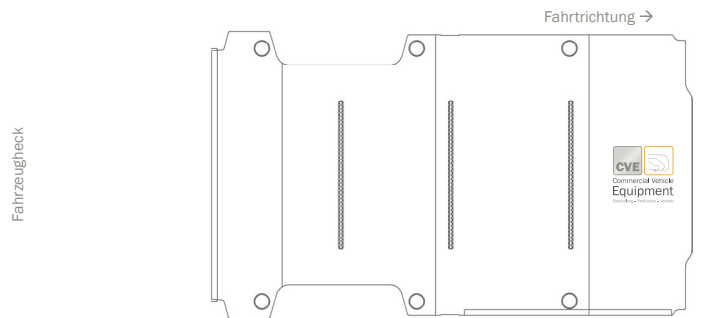

Ducato (DoKa)	L2	CVE Modell (Typ)
RS: 3450		121

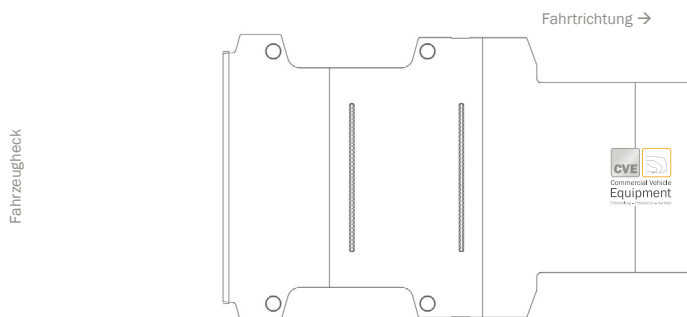

Ducato	L4	CVE Modell (Typ)
RS: 4035		122

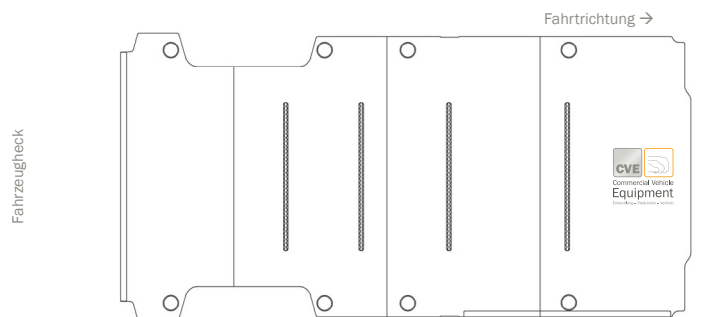

Ducato (DoKa)	L4	CVE Modell (Typ)
RS: 4035		122

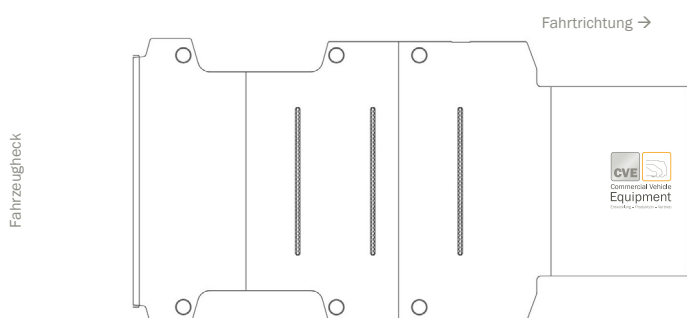

Ducato	L4	CVE Modell (Typ)
RS: 4035		122

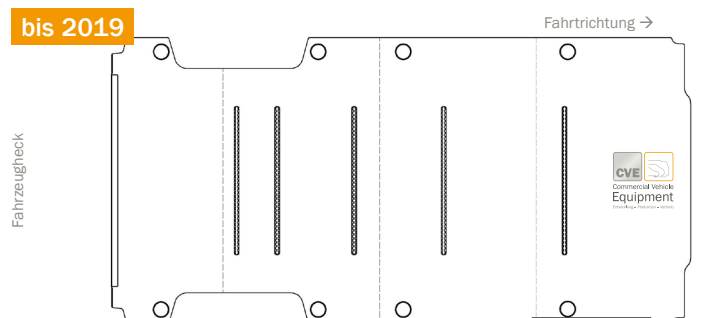

Ducato	L5	CVE Modell (Typ)
RS: 4035		123

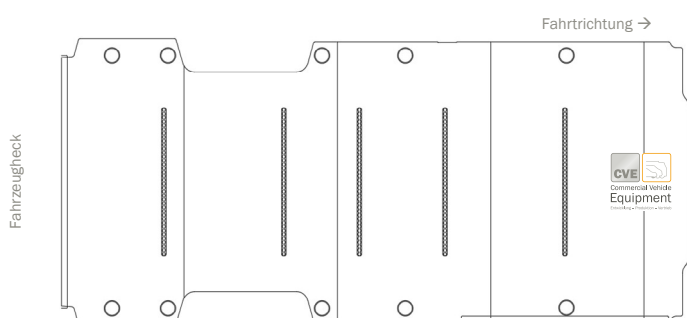

Ducato (DoKa)	L5	CVE Modell (Typ)
RS: 4035		123

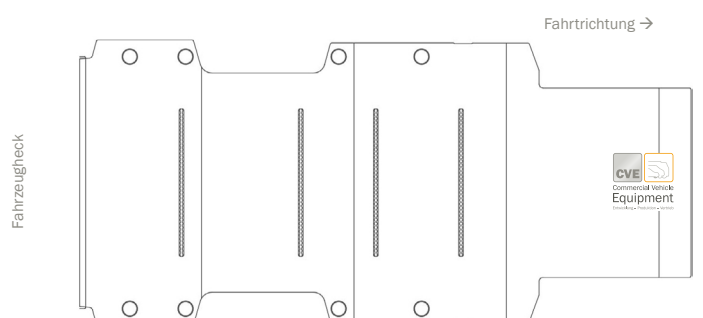

ZURRSCHIENEN BESTELLFORMULAR

Zurrschienen LRB, OEM Fiat, quer, Oberflur/Unterflur, lotrecht unter Dachholm

Commercial Vehicle
Equipment
 Entwicklung - Produktion - Vertrieb



Ducato	L5	CVE Modell (Typ)
RS: 4035		123

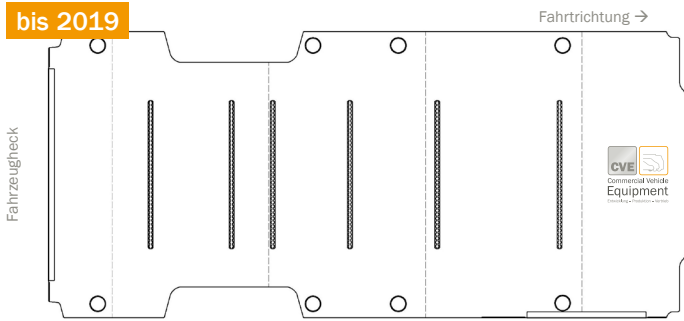

ZURRSCHIENEN BESTELLFORMULAR

Bitte füllen Sie alle Felder vollständig aus.

Commercial Vehicle
Equipment
Entwicklung - Produktion - Vertrieb



BESTELLER/IN

Firma

PLZ

Ort

Vor-/Nachname

Telefon

Straße und Hausnummer

E-Mail



Commercial Vehicle
Equipment
Entwicklung - Produktion - Vertrieb

**CVE Commercial Vehicle
Equipment GmbH & Co. KG**

Im Wied 9 (Halle 10)
32683 Barntrup
Deutschland / Germany

Tel.: +49 5263 - 900 98 - 0
Fax: +49 5263 - 900 98 - 10

info@cve-kg.de
www.cve-kg.de